

Product Information Bulletin 1008

GeoSpan and GeoVoid Compressible Fill Material

Product Information Bulletin

GeoSpan® and GeoVoid® Compressible Fill Material Design Provisions for Soil Movement

Page 1 of 2

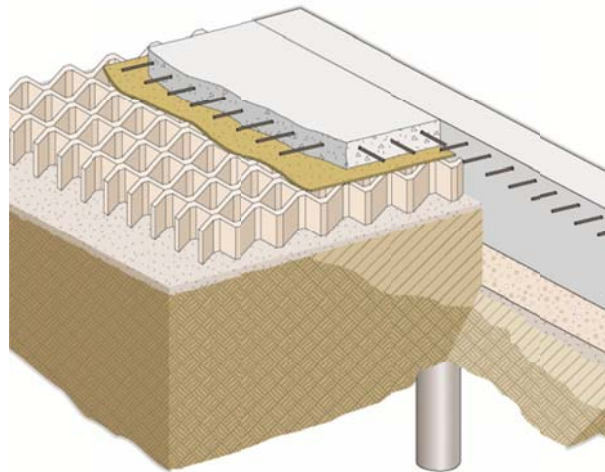

Where swelling or shrinking soils are known to be present, National Building Code of Canada (NBC) provisions require that soil movement be provided for in the design of structures likely to be damaged. **GeoSpan** and **GeoVoid** compressible fill material properties assist designers in addressing the NBC requirements as follows:

1. Plasti-Fab compressible fill materials are designed specifically to meet the structure requirements for each application.
2. Compressible fill materials are available in a range of compressive resistance to permit design for light structural to heavy structural elements.
3. Compressible fill material design criteria are provided for each application in a design summary for review by the project design engineer.
4. Compressible fill material properties are not affected by the presence of water on the short term nor are they dependent upon the presence of moisture on the long term.

GeoSpan® and **GeoVoid**® compressible fill materials are expanded polystyrene (EPS) products designed to act as a compressible medium between swelling soils and structural elements. Where long-term soil movement can be predicted, Plasti-Fab compressible fill materials can be designed to reduce the forces that would be induced on structures by soil movement thus reducing the likelihood of damage to the structure above.

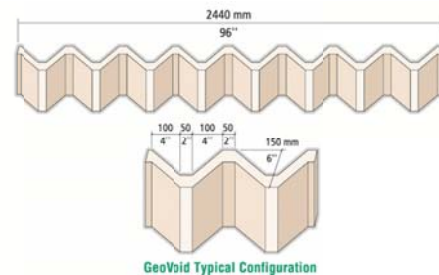

NBC Requirements

Part 4, Structural Design:

4.2.4.11. Swelling and Shrinking Soils

1) Where swelling or shrinking soils, in which movements resulting from moisture content changes may be sufficient to cause damage to a structure, are encountered or known to exist, such a condition shall be fully investigated and provided for in the design.

Part 9, Housing and Small Buildings:

9.4.4.4. Soil Movement

1) Where a foundation is located in an area where soil movement caused by changes in soil moisture content, freezing, or chemical-microbiological oxidation is known to occur to the extent that it will damage a building, measures shall be taken to preclude such movement or to reduce its effects on the building so that the building's stability and the performance of assemblies will not be adversely affected.

Required Project Data for GeoSpan and GeoVoid Compressible Fill Material Design

- Structure depth
- Structure weight + construction live load
- Anticipated long-term soil swell
- Structure design uplift resistance

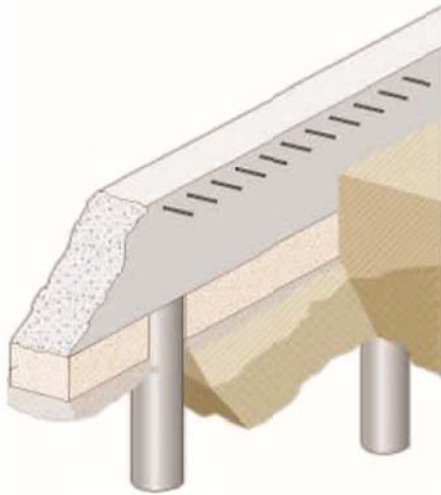

GeoSpan thickness (t) is determined using the equation:

$$t = \frac{\text{Soil Swell (mm)} \times 100}{\text{Final GeoSpan \% Strain}}$$

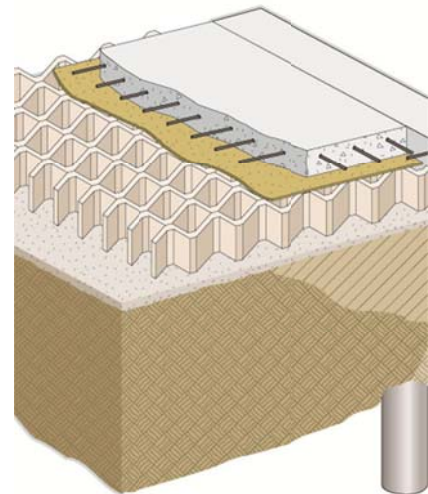
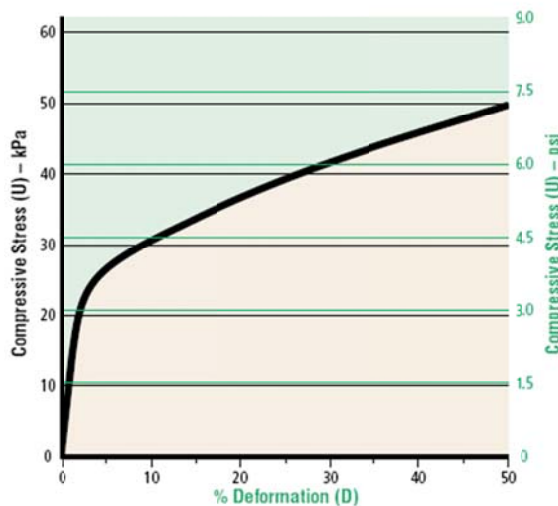

GeoVoid design for each application is determined based upon the thickness (t) and depth (d) of the GeoVoid compressible fill material.

